

受控熔断器

idea Thermal-Link (iTCO)

TPH***-R Series $I_T: 20 A$

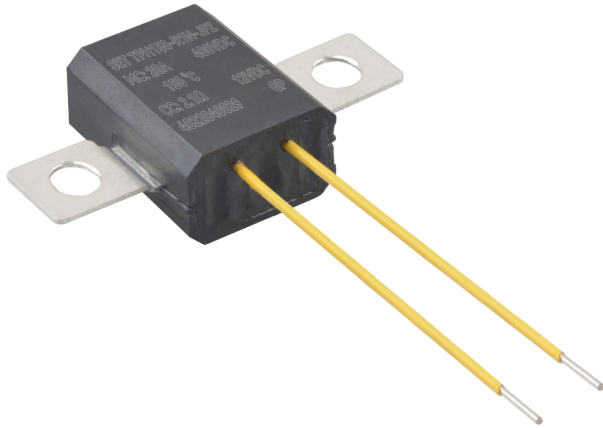

尺寸 Dimensions (mm)

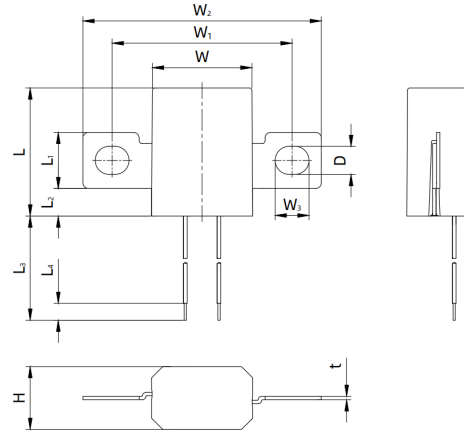

L	L ₁	L ₂	L ₃	L ₄	W	W ₁	W ₂	W ₃	t	D	H
22.8 ± 0.5	10.0 ± 0.2	4.8 ± 0.5	70.0 ± 5.0	5.0 ± 1.0	18.0 ± 0.5	32.0 ± 1.0	42.4 ± 1.0	6.0 ± 0.2	0.6 ± 0.1	5.0 ± 0.2	11.2 ± 0.5

结构图 Structure Diagrams

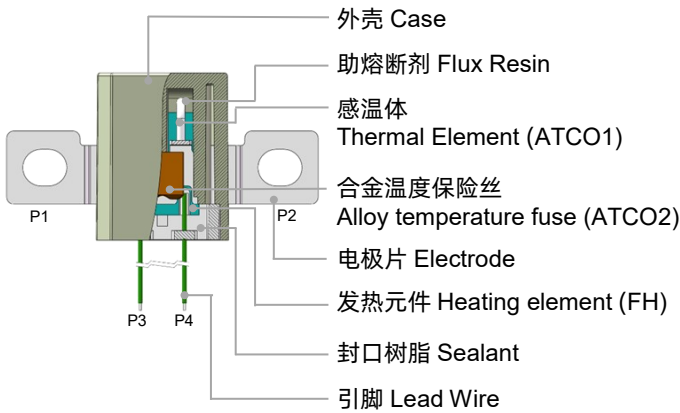

● P1 ~ P4 端口 Port

特性 Features

- 低阻抗, 低功耗
Low Impedance, Low Power Consumption
- MC受控熔断时间 ≤ 60 秒
MC Controlled Fusing Time ≤ 60 s
- 一次性动作而不可复位
Non-Resettable
- 主动控制
Active Control
- 过温保护
Over Temp. Protection
- 自控保护
Self-Control Protection
- 符合 RoHS & REACH
RoHS & REACH Compliant

产品原理图 Product Schematic

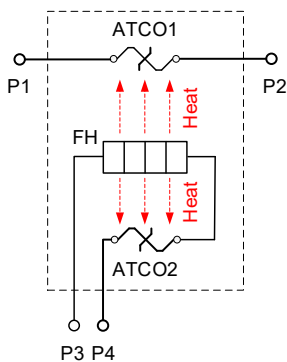

- P1 ~ P2 主电路 Main Circuit (MC)
- P3 ~ P4 控制电路 Control Circuit (CC)

应用 Application

- 电动摩托车、电动高尔夫球车
Electric Motorcycle, Electric Golf Cart
- 电动游艇、家庭储能
Electric Yacht, Household Energy Storage
- 基站电源、蓄电池
Base Station Power Supply, Battery

型号说明 Part Number System

iTCO - TPH150 - R 1 N - J P Z

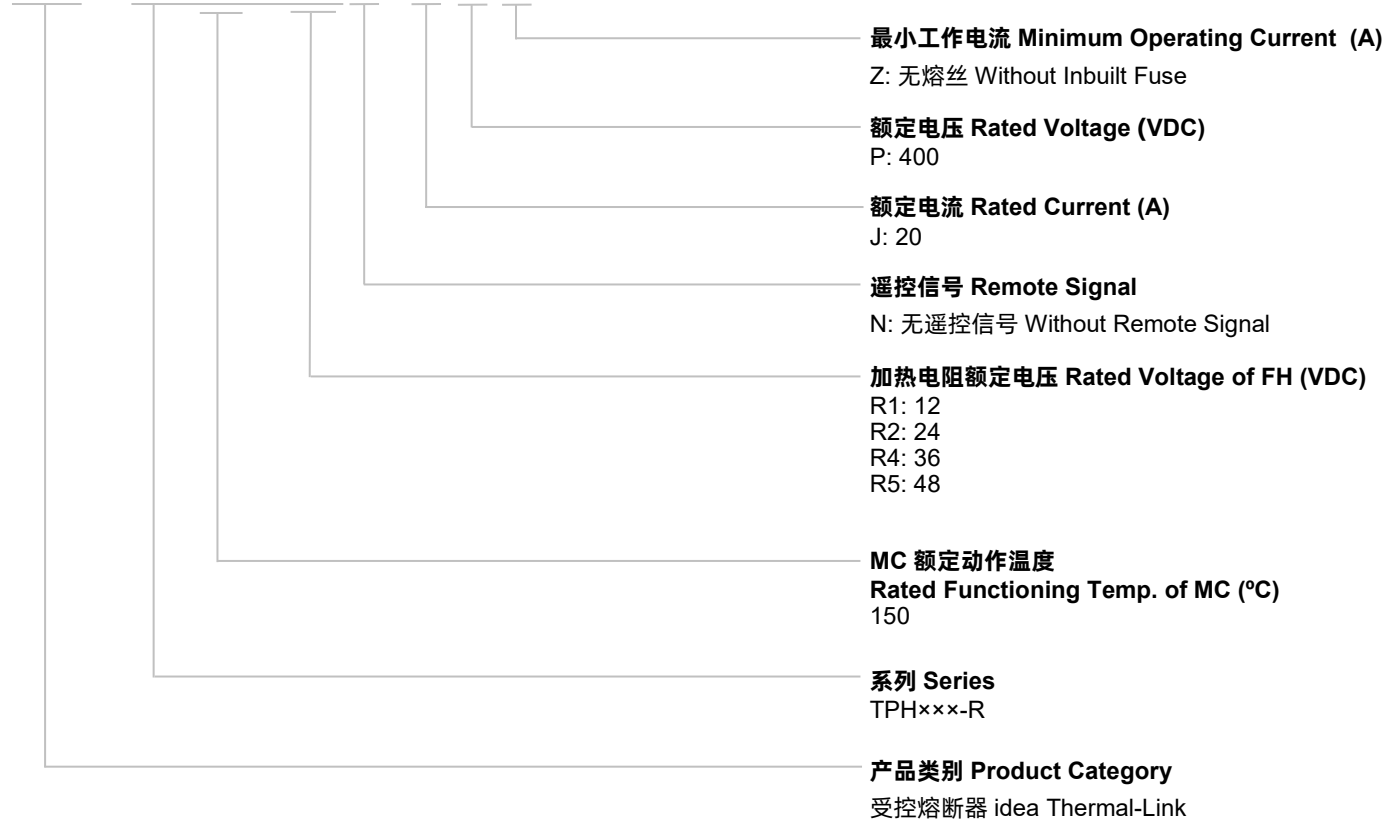

产品标示 Marking

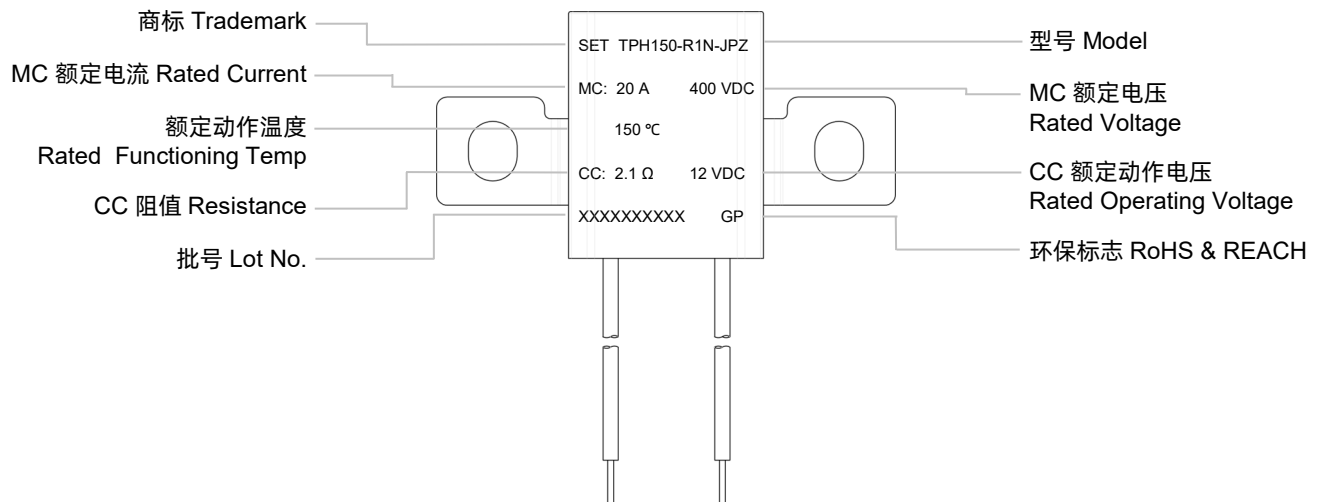

术语Glossary

项目 Item	说明 Description
iTCO	受控熔断器 idea Thermal-Link 接收控制信号后能自行熔断的保护器。 Protector that can fuse itself after receiving control signal.
TCO	热熔断体 Thermal-Link 热熔断体也称为热断路器或温度保险丝，在本文中这些不同名词都代表同样的产品，为一次性动作而不可复位的装置。 A non-resettable device incorporating a thermal which will open a circuit once only when exposed for a sufficient length of time to a temp. in excess of that for which it has been designed.
ATCO	合金型温度保险丝 Alloy type Thermal-Link 合金型温度保险丝，由易熔合金作为感温部件的热熔断体。 Alloy type Thermal-Link, Alloy is thermal element.
FH	发热元件 Feed Heater 利用电能达到加热效果的元器件。 Electric appliances that use electric energy to achieve heating effect.
MC	主电路 Main Circuit 电路中用作闭合或断开电路的开关器件的所有导电部件。 All conductive components used in switching devices for closing or disconnecting circuits in a circuit.
CC	控制电路 Control Circuit 除主电路外，接入电路中用作开关电器的闭合操作和、或断开操作的开关电器所有导电部件。 In addition to the main circuit, all conductive parts of the switching apparatus used in the access circuit as the closing operation and / or opening operation of the switching apparatus.
I_r	额定电流 Rated Current 受控熔断器分类用，允许用于电路并安全断开的最大电流。 The current used to classify an iTCO, which is the Maximum current that iTCO allows to carry and is able to cut off the circuit safely.
U_r	额定电压 Rated Voltage 受控熔断器分类用，允许用于电路并安全断开的最高电压。 The voltage used to classify an iTCO, which is the Maximum voltage that iTCO allows to carry and is able to cut off the circuit safely.
T_f	额定动作温度 Rated Functioning Temp. 通10 mA以下的负载电流时，加热使温度保险丝断开的温度。 The temperature of the Thermal-Link which causes it to change the state of conductivity with a detection current up to 10 mA as the only load. Tolerance: $T_f 0 / -10$ °C (GB 9816, EN 60691, K60691). Tolerance: $T_f \pm 7$ °C (J60691).
Fusing Temp.	实测熔断温度 Fusing Temp. 置于油池中，通10 mA以下的负载电流，每分钟升温(0.5 ~ 1) °C，测断开温度。 The temp. of the iTCO which causes it to change its state of conductivity is measured with silicone oil bath in which the temp. is increased at the rate of (0.5 to 1) °C /minutes, with a detection current less than 10 mA as the only load.
T_h	保持温度 Holding Temp. 持续通额定电流168小时不断开的最高温度。 The Maximum temp. at which iTCO will not change its state of conductivity when conducting rated current for 168 h.
T_m	极限温度 Maximum Temp. Limit 在规定的时间内不破坏机械和电气特性所能承受的最高温度。 The temp. of the iTCO stated by the manufacturer, up to which the mechanical and electrical properties of the iTCO having changed its state of conductivity, will not be impaired for a given time.

iTCO

iTCO

技术参数 Specifications

型号 Model	主电路参数 Main Circuit Specifications						控制电路参数 Control Circuit Specifications		熔断时间 Fusing Time	
	额定动作温度 T_r	实测熔断温度 Fusing Temp.	保持温度 T_h	极限温度 T_m	额定电流 I_r	额定电压 U_r	额定动作电压 Rated Operating Voltage U_r	阻值 Cold Resistance	t_{mc} (P1 ~ P2)	t_{cc} (P3 ~ P4)
	(°C)	(°C)	(°C)	(°C)	(A)	(VDC)	(VDC)	(Ω)	(s)	(s)
TPH150-R1N-JPZ	150	146 ± 3	85	180	20	400	12	2.1 ± 0.4	≤ 60	$t_{mc} + (0 \sim 30)$
TPH150-R2N-JPZ	150	146 ± 3	85	180	20	400	24	8.0 ± 1.5	≤ 60	$t_{mc} + (0 \sim 30)$
TPH150-R4N-JPZ	150	146 ± 3	85	180	20	400	36	18.0 ± 3.0	≤ 60	$t_{mc} + (0 \sim 30)$
TPH150-R5N-JPZ	150	146 ± 3	85	180	20	400	48	32.0 ± 5.0	≤ 60	$t_{mc} + (0 \sim 30)$

产品电流-时间曲线 (仅供参考) Product Current-Time Curve (Reference)

描绘了受控熔断器在 (25 ± 2) °C 室温中, 不同倍数额定电流下的断开时间。

The Current-Time Curve shows functioning time at multi-times rated current at room temperature (25 ± 2)°C.

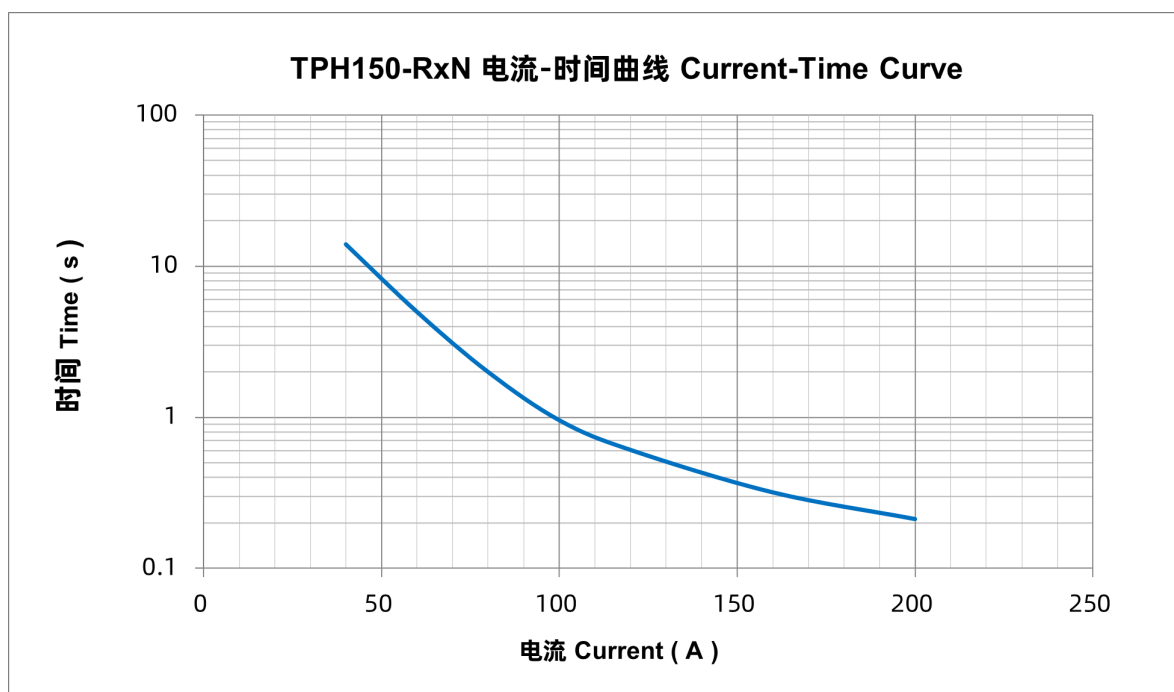

受控熔断器

idea Thermal-Link (iTCO)

TPHxxx-R Series I_t : 20 A

包装信息 Packing Information

项目 Item	吸塑盘 Tray	PE袋 Bag	外箱 Carton
尺寸 Dimensions (mm)	345 × 250 × 15	345 × 250 × 55	370 × 275 × 410
数量 Quantity (PCS)	16	80	400
毛重 Gross Weight (kg)			4.3 ± 10 %

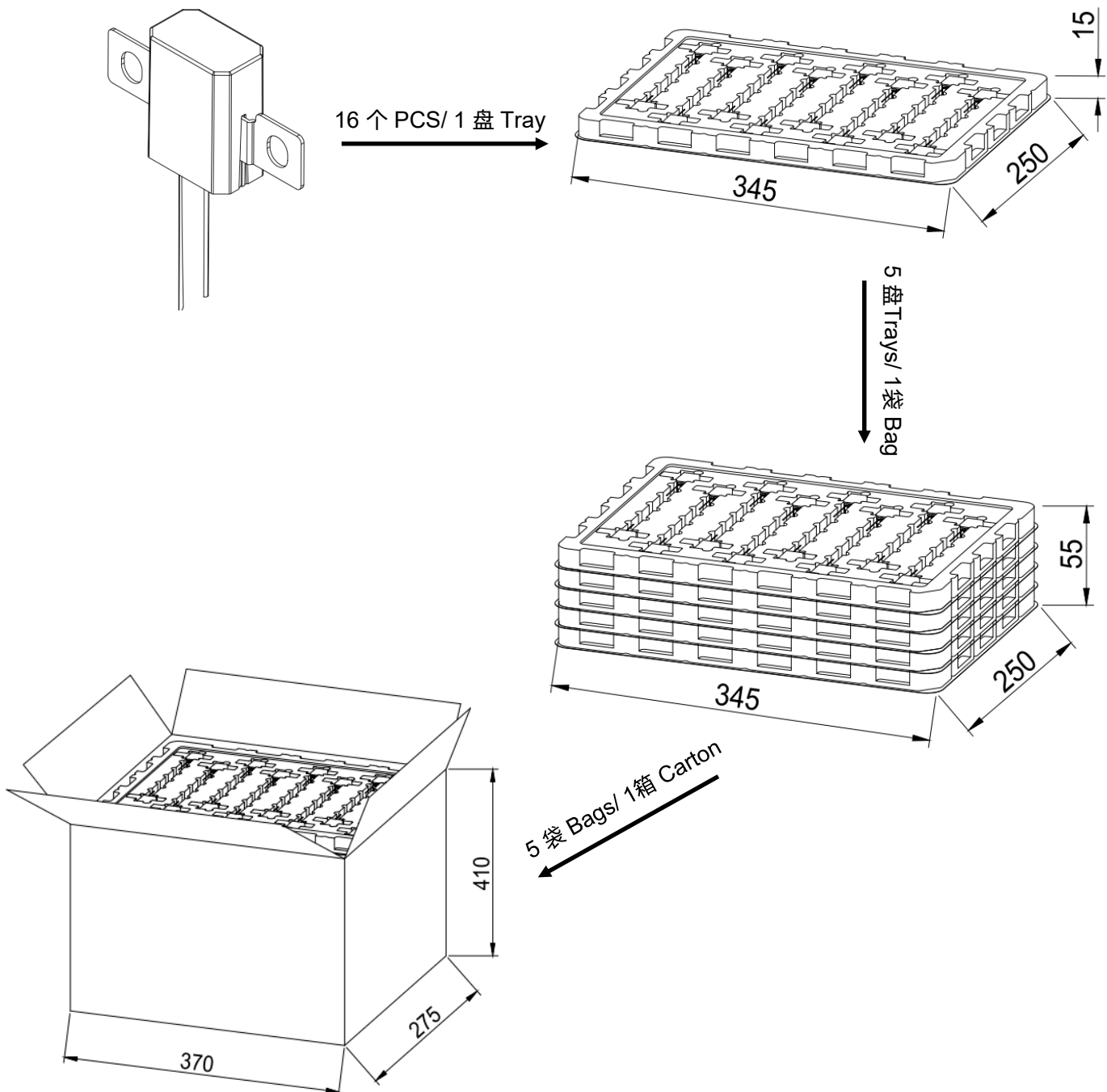

iTCO

iTCO



注意

ATTENTION

使用方法 Usage

1. 大气压：(80 ~ 106) kPa, 海拔高度：(-500 ~ 2000) m。
When atmosphere press is from 80 kPa to 106 kPa, the related altitude shall be from 2,000 meter to -500 meter.
2. 工作电压/工作电流应小于额定电压/额定电流。
Operating voltage shall be less than rated voltage of iTCO, operating current shall be less than rated current of iTCO.
3. 通电时请勿直接触摸iTCO本体或引线，以免引起灼伤或触电。
Do not touch the iTCO body or electrode lead directly when power is on, to avoid burn or electric shock.

电气连接 Electrical Connections

机械连接 MC Mechanical Connection MC

1. 产品表面无损坏。
The product surface must not be damaged.
2. 如果在电极片上增加端子，请确保电极片上没有油脂或其他异物，并使用相同截面的连接端子，否则电极片可能会异常发热。
If adding terminals to electrode leads, make sure the electrode without grease or other foreign matters, and use the same cross-section connection terminal, otherwise the electrode may heat abnormally.
3. 如果用螺钉锁紧以防止松动，请在安装产品时添加垫圈并使用适当的螺钉，且需确保螺钉锁紧的扭矩满足要求。
If locking with screw, to prevent loosening, please add gasket and use proper screw when installing the product. Ensure that the screw tightening torque meets the requirements.

焊接 CC Soldering CC

1. 焊接应在表-1中列出的焊接条件下进行。
Soldering should be carried out under the soldering conditions listed in table -1.
2. 控制电路 CC, 包含易熔合金, 若焊接操作不当 (焊接温度过高, 焊接时间过长, 引线太短等) 可能会导致 CC 提前断开。
Feed heater and remote signal CC, improper soldering operation (too high soldering temperature, too long soldering time, too short lead wire etc.) may cause CC to open in advance.
3. 当焊接条件比表-1中列出的条件更严苛时, 应在焊点和iTCO主体之间使用散热器固定装置。
When soldering conditions are more severe than those listed in table -1, a heat sink fixture should be used between solder point and iTCO body.

表-1手工焊接时间 Table -1 Hand - Soldering Time (s)

不同引线长度的最大允许焊接时间(s) The Max. Allowable Soldering Time for Different Lead Length (s)						最高焊接温度 Max. Soldering Temp.
引线长度 Lead Length	最大允许焊接时间 Max. Allowable Soldering Time	引线长度 Lead Length	最大允许焊接时间 Max. Allowable Soldering Time	引线长度 Lead Length	最大允许焊接时间 Max. Allowable Soldering Time	
(mm)	(s)	(mm)	(s)	(mm)	(s)	(°C)
≤10	8	10 ~ 20	9	20 ~ 30	9	400

测试方法 Test Methods

电阻测试 Cold Resistance Test

1. 如果产品的电阻温度系数不低于350 E (-6) / °C, 并且测试环境温度在15 °C 至35 °C 之间, 应根据电阻温度系数公式将测得的电阻值校正为25 °C 下的相对电阻值。
If product TCR is not less than 350 E (-6) / °C and the test ambient Temperature is during 15 °C to 35 °C, the measured resistance value shall be corrected as the relative resistance value under 25 °C according to TCR formula.
2. 电阻测量 (四探针)
Resistance measurement (Four - point probe).

更换 Replacement

受控熔断器是不可修复的产品。基于安全原因, 请使用同型号的受控熔断器进行替换。
iTCO is the non-resettable product, for safety sake, please use the same type of iTCO for replacement.

存贮 Storage

受控熔断器必须避免日光照射及污染的环境, 且在温度(10 ~ 30) °C、湿度(30 ~ 70)%的条件下保存, 以免影响引线的可焊性和接触电阻。产品应在收到货物后一年内使用。
iTCO must be kept in a place with no sunshine or no pollution, with temp. (10 to 30) °C and humidity within (30 to 70) %. To avoid influencing the solder-ability of the leads and influencing contact resistance, please use them up within 1 year after receiving the goods.